

Clean Development Mechanism South Africa  
Designated National Authority



energy

Department:  
Energy  
REPUBLIC OF SOUTH AFRICA

Private Bag X 19 , Acardia ,Pretoria, 0007, Tel:012-444 4116, Fax: 012 444 4501  
Private Bag X9111, Cape Town, 8000, Tel: 021-469 6412, Fax: 021-465 5980

## Project Design Document (PDD)

Project reference number (office)	
Date received (office use only)	

### NOTES ON COMPLETING THIS PROJECT DESIGN DOCUMENT

1. Please provide this PDD in both hard-copy (one copy) and electronic formats (MSWord)

### Part A: Project Proponent Details

Project Name	Tongaat Hulett Sugar Refinery Steam Optimisation Project
Date of Submission of PDD	01 November 2012

Project Developer	
Name	Tongaat Hulett Sugar South Africa Limited
Organizational Category	Public Company
Legal Status	Limited Liability
Street Address	Amanzimnyama Hill Road Tongaat KwaZulu-Natal
Postal Address (if different from above)	Private Bag 3 Glenashley 4022
Website Address	<a href="http://www.huletts.co.za">www.huletts.co.za</a>

<b>Main Activities</b>	Tongaat Hulett Sugar South Africa Limited's main activities are the farming of sugarcane and the milling and refining of sugarcane to refined white sugar and other sugar related products. Tongaat Hulett Sugar South Africa Limited is a level 2 B-BBEE contributor.
<b>Summary of Financial Performance in last fiscal year</b>	Summary of Financials taken from the 2012 Tongaat Hulett Sugar South Africa Limited's Annual Report: Total Assets (Non Current & Current): R17 782 million Total Revenue: R12 081 million Net Profit: R1 021 million
<b>Contact Person(s)</b>	Craig Jensen
<b>Telephone</b>	Work: +27 32 439 4337 Cell: +27 83 386 8374
<b>Fax</b>	+27 (0) 86 644 0337
<b>Email Address</b>	<a href="mailto:craig.jensen@tongaat.com">craig.jensen@tongaat.com</a>
<b>Project Partners</b> Provide the following Information for all project partners (copy and paste relevant sections of the table if information is to be provided on more than one partner organisation)	
<b>Name</b>	
<b>Nature of partner</b>	
<b>Organizational Category</b>	
<b>Legal Status (if private company)</b>	
<b>Street Address</b>	
<b>Postal Address (if different to Street Address)</b>	
<b>Website Address</b>	
<b>Main Activities</b>	
<b>Contact Person(s)</b>	
<b>Telephone</b>	
<b>Fax</b>	
<b>Email Address</b>	
<b>Contractual Arrangements</b>	
<b>Contractual arrangements between various entities involved</b>	The project owner, Tongaat Hulett Sugar South Africa Limited, has only contract external consultants to assist with the carbon project development process. Tongaat Hulett Sugar South Africa Limited will own all of the carbon credits (CERs) that would be generated from the project.

## Part B: Project Overview (Technical Summary, Location and Schedule)

<b>Technical Summary of the project</b>	
<b>Objective of the Project</b>	The objective of the project is to reduce anthropogenic greenhouse gas emissions as a result of the combustion of coal on site at the Tongaat Hulett Sugar Refinery (HulRef) by implementing cooling crystallization and multiple effect evaporators, reducing the primary steam demand of the sugar crystallization process and

## Technical Summary of the project

changing the energy source for the evaporation process from primary steam from the boilers to waste heat vapours.

### Project Description

The Tongaat Hulett Sugar South Africa Limited's Engineering Group have identified a step change to the process of refining raw sugar to refined white sugar. This process step change is a first of its kind technology that will use cooling crystallization as an alternative to evaporative crystallization. The use of cooling crystallization allows for the decoupling of the evaporation and crystallization stages of the white sugar refining process.

This decoupling allows for the use of waste heat vapours in a multiple effect evaporator system. This use of waste heat vapours displaces the current energy source being used for performing evaporation, the primary steam generated by coal fired boilers. The multiple effect evaporators also allows for the increased use of waste heat within the refinery.

The new technology and design, known as GREEN Refining Technology is intended to be implemented at the Tongaat Hulett Sugar South Africa Limited's central sugar refinery, HulRef, in Durban. GREEN Refining Technology will be used to supplement the current single effect evaporative crystallizers that are used with the white sugar refinery. The evaporative crystallizers have specific temperature requirements and as such cannot use waste heat vapour as an energy source. This will change the energy source in many areas of the refinery, particularly the evaporation area from primary steam from the boilers to waste heat vapours. The overall effect will be the reduction of primary steam demands of the refinery therefore reducing the associated greenhouse gas emissions from the combustion of coal for the generation of primary steam.

The project will be implemented in two phases, with the first phase expected to be complete by October 2014 and the second phase by October 2016.

The flow sheet below shows the new process flow for the refinery (shown in red blocks) and the integration into the current flow sheet.

## Technical Summary of the project

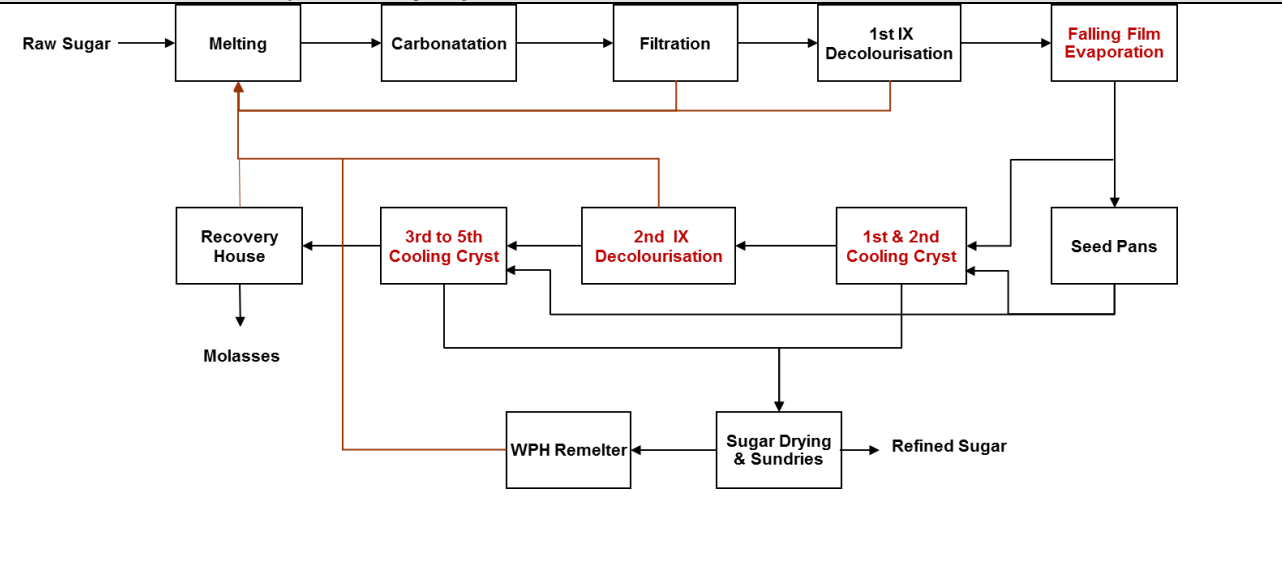

### Project Constraints

The major constraint to the implementation of the project is the technological risk associated with implementing a first of its kind technology (an energy source change within many areas of the refinery from primary steam to waste heat) internationally in the sugar refining process. Failure of this new use of technology would significantly affect the project owner as it is their primary business operation and they would be unable to refine the majority of the sugar that they currently refine.

### Technology to be employed

The technology to be employed is multiple effect falling film evaporators and cooling crystallizers to supplement the current single effect evaporative crystallizers. The combination of the new technology is referred to as GREEN Refining Technology and is currently patent pending.

Multiple effect falling film evaporators and cooling crystallization have been used in other sugar process environments internationally and nationally, but this combination have not been used in the sugar refining process anywhere in the world as demonstrated by the patent pending status of the technology and subsequent literature reviews presented in the PDD.

The technology has been developed by the Project Owner's engineering department and as such they will develop experience in operating it.

### Greenhouse Gases Targeted

Carbon Dioxide (CO<sub>2</sub>)

### Emission reductions

Annual Expected Emissions Reductions: 147 719 tCO<sub>2e</sub>  
 Total Expected Emissions Reductions (10 years): 1 477 190 tCO<sub>2e</sub>

### Baseline & Additionality

Using the Combined tool to identify the baseline scenario and

<b>Technical Summary of the project</b>	
<b>Assessment</b>	<p>demonstrate additionality” version 04.0.0. and Guidelines on Additionality of First-Of-Its-Kind Project Activities version 02.0 from 13 September 2012, the project baseline and additionality was assessed.</p> <p>All alternative scenarios were examined and it was concluded that the baseline scenario is the continuation of the current scenario. This conclusion was reached as Tongaat Hulett Sugar South Africa Limited has implemented many energy efficiency initiatives over the past two decades and has investigated many energy efficiency alternatives that have been disregarded for various reasons. Some alternatives have been implemented and subsequently failed. This is shown by the internal energy audit conducted by Tongaat Hulett Sugar South Africa Limited.</p> <p>The project has been assessed using the Guidelines on Additionality of First-Of-Its-Kind Project Activities. It was concluded that the project is a first-of-its-kind technology and is therefore additional. This conclusion was reached based on the fact that the project changes the energy source of the evaporation steps in the refinery from primary boiler generated steam to waste heat vapours. This change of energy source meets the criteria for a different technology and it is demonstrated through third party experts and literature that this technology has not been implemented globally before.</p>
<b>Monitoring</b>	<p>The following parameters will be continuously monitored</p> <ul style="list-style-type: none"> <li>• Steam consumption and used in the white sugar refinery (per shift)</li> <li>• Steam generation by the six boilers at the white sugar refinery (per shift)</li> <li>• Steam consumed by the fructose plant (per shift) (excluded from the project boundary)</li> <li>• Production of refined white sugar (per shift)</li> <li>• Specific Steam Consumption (per shift)</li> <li>• Electricity imported per year and used in the white sugar refinery (annual)</li> <li>• Electricity consumed by the fructose and white sugar refinery (annual)</li> <li>• Electricity generated by the turbines on the site (Annual)</li> <li>• Enthalpy of the boiler feed water and steam outputs of all six boilers (Daily)</li> <li>• Calorific value and carbon content of coal used in the boilers to generate steam (Yearly average)</li> <li>• Quantity of coal used in the boilers (daily)</li> <li>• Annual white sugar production in tonnes (annual)</li> <li>• Boiler efficiency using the direct method (daily)</li> <li>• Number of shifts per day</li> </ul>
<b>Type of project/activities</b>	Identify which type of activity is involved in this project - and for each, provide brief details
a. Energy Supply	Not Applicable

<b>Technical Summary of the project</b>	
b. Energy Demand	Select if applicable: other  Reduction in specific steam demand within an industrial process through the implementation of new sugar crystallization methods.
c. Industrial Process	Not Applicable
d. Transport	Not Applicable
e. Waste Management	Not Applicable
f. Forestry/ land use	Not Applicable
g. Other	Not Applicable
<b>Project Boundary</b>	
Included in the project boundary are the following: <ul style="list-style-type: none"> <li>• The white sugar refinery including the following <ul style="list-style-type: none"> <li>○ Coal fired boilers</li> <li>○ Turbines providing electricity to the white sugar refinery</li> <li>○ Entire white sugar refining process, including the new cooling crystallization and falling film evaporator station, but excluding the fructose plant</li> <li>○ Grid supplied electricity to the white sugar refinery</li> </ul> </li> </ul>	
Indicate Emissions outside the Project Boundary	None expected.

<b>Location of the Project</b>	
Province	Kwazulu-Natal
Municipality	eThekweni Municipality
Nearest city/large town	Durban
Brief description of the location of the project site	HulRef 444 South Cost Road, Rossburgh, Durban GPS Coordinates: 29° 54'28" S 30° .58'37"E

<b>Project Schedule/Timetable</b>	
Earliest Project Start Date	01 October 2014, once Phase 1 of the project is commissioned
When is the expected first year of CER delivery	2014
Project Lifetime	10 Years
Project End Date	September 2024
Crediting Period	10 years only
Current Status or phase of the project	The project is under discussion and being planned at the moment by the Tongaat Hulett Sugar South Africa Limited Engineering Team. Tongaat Hulett Sugar South Africa Limited is currently awaiting a decision by the board on the implementation of a demonstration plant.

Project Schedule/Timetable	
DNA Approval	Yes, for voluntary screening.  A Letter of No Objection was issued by the DNA on 20 September 2012. This letter requested further information in the mandatory submission on the level of participation and ownership in the project of Historically Disadvantaged South Africans.
Approval by other bodies	No

## Part C: Performance Against the DNA's Sustainable Development Criteria

South Africa has identified the following sustainable development criteria and indicators against which each CDM project will be assessed. Please provide your interpretation of how this project will address each of these criteria and indicators where they are relevant to the project. If the space provided is not sufficient please append additional information as required.

**NOTE:** For all indicators which are of relevance to the project show how the performance of the project against these indicators can be objectively monitored and measured on an ongoing basis.

### 1. Economic: Does the project contribute to national economic development?

Yes. The project will result in improved efficiency of the coal usage in South Africa that will result in improved efficiency in the sugar refining process. The technology will be developed in South Africa and could potentially be sold internationally, allowing South Africa to further itself as an international technology supplier and attract further economic investment. In addition, Tongaat Hulett Sugar South Africa Limited, the project owner, is a Level 2 Broad Based Black Economic Empowerment contributor and preference will be given to local suppliers who conform with Tongaat Hulett Sugar South Africa Limited's procurement policy with regards to B-BBEE and who conform with the technical requirements for the project. It is expected that a significant portion of the projects local fabrication, manufacture and install will benefit Historically Disadvantaged South Africans through preferential procurement and skills development, both in line with the current policies of Tongaat Hulett Sugar South Africa Limited.

### 2. Social: Does the project contribute to social development in South Africa?

Yes. The project will create short term jobs, approximately 25 over the 2 year construction process. In addition local fabricators will be used that will promote skills transfer to the fabricators. Additionally, the workers who will be responsible for implementing and operating the new, world first, technology will also be significantly up-skilled. The reduced environmental pollution in the area through reduced greenhouse gas emissions and coal combustion will result in improved social environments for the local community who have complained about the emissions from the refinery in the past.

<p><b>3. Environmental: Does the project conform to the National Environmental Management Act principles of sustainable development? Yes</b> Please provide brief comment for each of these below.</p>	
<p>i) That the <b>disturbance of ecosystems and loss of biological diversity</b> are avoided, or where they cannot be avoided, are minimised and remedied</p>	<p>The project is a retrofit of the current refinery and as such there is no disturbance of ecosystems or loss of biological diversity.</p>
<p>ii) That <b>pollution and degradation of the environment</b> are avoided, or where they cannot be altogether avoided, are minimised and remedied</p>	<p>The project will result in far less combustion of coal and as such will reduce environmental pollution and degradation once implemented through the reduction of anthropogenic greenhouse gas emissions.</p>
<p>iii) That the <b>disturbance of landscapes and sites that constitute the nation's cultural heritage</b> is avoided, or where it cannot be altogether avoided, is minimised and remedied</p>	<p>The project is a retrofit of the current refinery and as such there is no disturbance of landscapes that contribute to the nation's cultural heritage.</p>
<p>iv) That <b>waste is avoided</b>, or where it cannot be altogether avoided, minimised and reused or recycled where possible and otherwise disposed of in a responsible manner</p>	<p>The project is a retrofit of the current refinery and as such there is no additional waste generated. No equipment will be scrapped or removed from the refinery during the project.</p>
<p>v) That the <b>use and exploitation of non-renewable resources is responsible and equitable</b>, and takes into account the consequences of the depletion of the resource</p>	<p>The project is a retrofit of the current refinery that reduces coal consumption, a non renewable resource. The refinery will therefore use coal more responsibly as the efficiency of coal usage will increase by over 50% to get the same sugar output.</p>
<p>vi) That the <b>development, use and exploitation of renewable resources is responsible and equitable</b>, and takes into account the consequences of the depletion of the resource.</p>	<p>No renewable resources used.</p>
<p>vii) That a <b>risk averse and cautious approach</b> is applied, which takes into account the limits of current knowledge about the consequences of decisions and</p>	<p>The project is a retrofit of the current refinery and the project owner is carefully designing the retrofit to ensure that all risks are identified and mitigated.</p>

actions	
vii) That <b>negative impacts on the environment and on people's environmental rights</b> be anticipated and prevented, and where they cannot be altogether prevented, are minimised and remedied	No negative impacts are expected.
<b>Other comments</b> None	

### Indicators in Support of the Project Approval Criteria

Category	Indicator	Comment	
<b>Environmental</b>	Impact on local environmental quality	<ul style="list-style-type: none"> <li>• Impact of the project on air quality</li> <li>• Impact of the project on water pollution</li> <li>• Impact of the project on the generation or disposal of solid waste</li> <li>• Any other positive or negative environmental impacts of the project (such as impacts on noise, safety, visual impacts, or traffic)</li> </ul>	The reduction in the combustion of coal in the boilers (expected to be over 50%) will result in reduced air pollution and therefore increase the air quality in the region. The reduced coal consumption will also result in fewer emissions from the transport of coal to the refinery. By reducing the steam consumption in the facility, water usage is also reduced.
	Change in usage of natural resources	<ul style="list-style-type: none"> <li>• Impact of the project on community access to natural resources</li> <li>• Impact of the project on the sustainability of use of water, minerals or other non renewable natural resources</li> <li>• Impact of the project on the efficiency of resource utilisation</li> </ul>	The project will result in the reduction of coal usage, a non renewable natural resource in South Africa. The reduction in steam consumption in the refinery will reduce water consumption of the facility and therefore water consumption of the region. The refinery will produce the equivalent amount of sugar using far less coal, therefore improving the efficiency of coal utilisation.
	Impacts on biodiversity and ecosystems	<ul style="list-style-type: none"> <li>• Changes in local or regional biodiversity arising from the project</li> </ul>	The project will not impact the biodiversity and ecosystems in the region as it is an upgrade to the current refinery.

### Indicators in Support of the Project Approval Criteria

Category	Indicator	Comment
Economic	Economic impacts	<ul style="list-style-type: none"> <li>Impact of the project on foreign exchange requirements</li> <li>Impact of the project on existing economic activity in the area</li> <li>Impact of the project on the cost of energy</li> <li>Impact of the project on foreign direct investment</li> </ul> <p>The project will result in short term jobs for the implementation of the new design over the two year construction period. The quantity of jobs is expected to be 25 over the project period. The project will have no impact on the cost of energy other than reducing the coal usage of South Africa. In addition, Tongaat Hulett Sugar South Africa Limited, the project owner, is a Level 2 Broad Based Black Economic Empowerment contributor and preference will be given to local suppliers who conform with Tongaat Hulett Sugar South Africa Limited's procurement policy with regards to B-BBEE and who conform with the technical requirements for the project. It is expected that a significant portion of the projects local fabrication, manufacture and install will benefit Historically Disadvantaged South Africans through preferential procurement and skills development, both in line with the current policies of Tongaat Hulett Sugar South Africa Limited.</p>

**Indicators in Support of the Project Approval Criteria**

Category	Indicator	Comment
	<p align="center">Appropriate technology transfer</p> <ul style="list-style-type: none"> <li>• Positive or negative implications for the transfer of technology to South Africa arising from the project</li> <li>• Impacts of the project on local skills development</li> <li>• Demonstration and replication potential of the project</li> </ul>	<p>The project has been designed locally by the Tongaat Hulett Sugar South Africa Limited engineering staff that will result in technology transfer to local South Africans who will be responsible for fabricating, installing and operating the new refinery process. The current refinery operators will be significantly up-skilled as the new process and energy sources will increase in complexity. The project is a first of its kind technology internationally that could be repeated in other central refineries around the world promoting skills transfer from South Africa.</p>

### Indicators in Support of the Project Approval Criteria

Category	Indicator	Comment
Social	<p style="text-align: center;">Alignment with national provincial and local development priorities</p> <ul style="list-style-type: none"> <li>• How the project is aligned with provincial and national government objectives</li> <li>• How the project is aligned with local developmental objectives</li> <li>• Impact of the project on the provision of, or access to, basic services to the area</li> <li>• Impact of the project on the relocation of communities if applicable</li> <li>• Contribution of the project to a any specific sectoral objectives (for example, renewable energy targets)</li> </ul>	<p>The government has published the white paper on climate change that identifies the need for a reduction in greenhouse gas emissions. The proposed project will significantly reduce greenhouse gas emissions that will aid in the country meeting the 34% reduction target that has been set. The significantly improved efficiency of the refinery assists in meeting local environmental goals and emission reductions in the Durban area, particularly in the environmentally sensitive South Durban Basin.</p>

### Indicators in Support of the Project Approval Criteria

Category	Indicator	Comment
<p style="text-align: center;">Social equity and poverty alleviation</p>	<ul style="list-style-type: none"> <li>• Impact of the project on employment levels? (specify the number of jobs created/lost; the duration of time employed, distribution of employment opportunities, types of employment, categories of employment changes in terms of skill levels and gender and racial equity)</li> <li>• Impact of the project on community social structures</li> <li>• Impact of the project on social heritage</li> <li>• Impact of the project on the provision of social amenities to the community in which the project is situated</li> <li>• Contribution of the project to the development of previously underdeveloped areas or specially designated development nodes</li> </ul>	<p>The project will result in no job losses from the refinery and will result in the creation of temporary jobs (25) during the fabrication and construction phase of the new equipment and refining process. These jobs will vary between skilled and semi skilled jobs as well as labourers. The project will impact social heritage as it will be a world first project developed in the area that the country could be proud of as it has the potential to significantly reduce environmental impacts of the sugar refining process throughout the world.</p>

### Indicators in Support of the Project Approval Criteria

Category	Indicator	Comment
General	General Project Acceptability <ul style="list-style-type: none"><li data-bbox="506 553 890 634">• Are the distribution of project benefits deemed to be reasonable and fair?</li></ul>	Yes the distributions are fair as the project owner is taking on significant technological risks in order to reduce coal consumption at the refinery. This will result in improved environmental quality in the region, in particular air quality.

## Part D: Finance

Project Costs	
Development Costs (R's )	Completed Internally by Tongaat Hulett Sugar South Africa Limited
Installed Costs (R's)	Approximately R315 million, including all design, prototyping and development
Other Costs (R's)	None
Total Project Costs (R's)	R315 million
Sources of Finance	
Equity	To be part funded by Tongaat Hulett Sugar South Africa Limited, although a final investment decision has not yet been made in this regard. The remainder will be financed through debt.
Debt (long term)	To be confirmed
Debt (short term)	To be confirmed
Amount not identified (R's)	To be confirmed
Total CDM Contribution sought	None expected for the capital requirements
Expected Price of CER in case of a contract to purchase for: A period of 7 years A period of 10 years A period of 14 years (2x7 years)	No contract in place.
Indicate the <b>projected Internal Rate of Return</b> for the project with and without CER revenues.	With CER Revenue: 21% - expected average CER price of €5 per CER Without CER Revenue: 18%  It must be noted that these numbers are based on high level provisional financial assessments as the final design and costing has not been completed yet.
Constraints on tradability of carbon credits	None
Preliminary discussions with potential purchasers	None